

DOLFA – 45V – R0.25

Frezy kątowe symetryczne do frezowania rowków 45° z promieniem naroży ostrzy R0,25 w próbkach udarowościowych Charpy'ego z karbem w kształcie litery V, wykonane metodą szlifowania

Form milling cutters for notched-bar impact test, accurate ground design

Formfräser für Kerbschlag-Biegeproben, hinterschlifene Genauigkeitsausführung

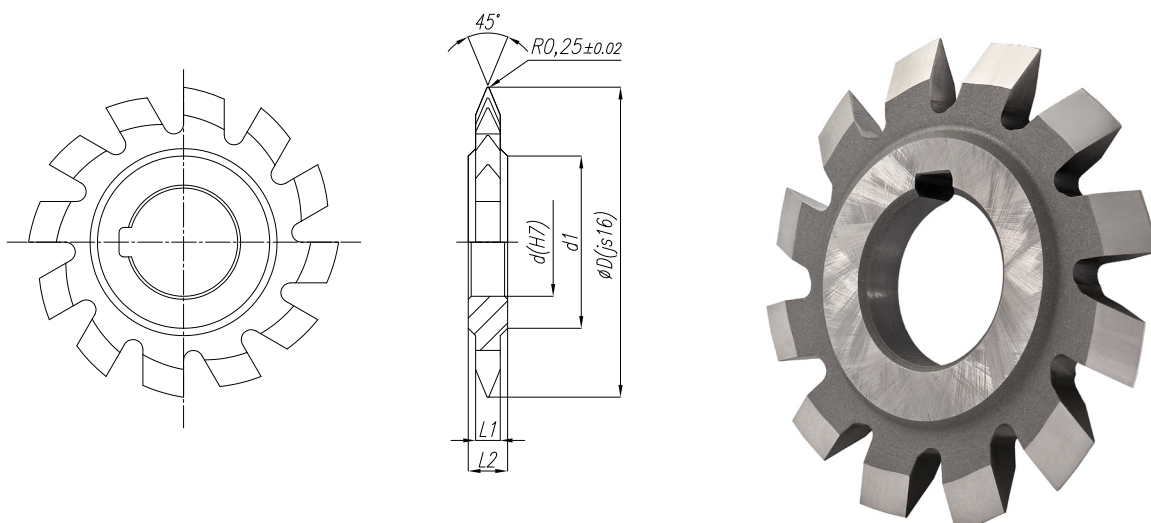

D (js16)	d (H7)	d1	L1	L2	z	HSS-E	
						Code No 0641-572-	
63	22	35	5	8 ±0,05	12	050103	●
75	27	45	5	10 ±0,05	14	050205	○
80	27	50	5	10 ±0,05	14	050307	●
93	27	61	5	12 ±0,05	18	050409	○
100	32	66	5	14 ±0,05	18	050500	●

DOLFA – 45V – R0.25

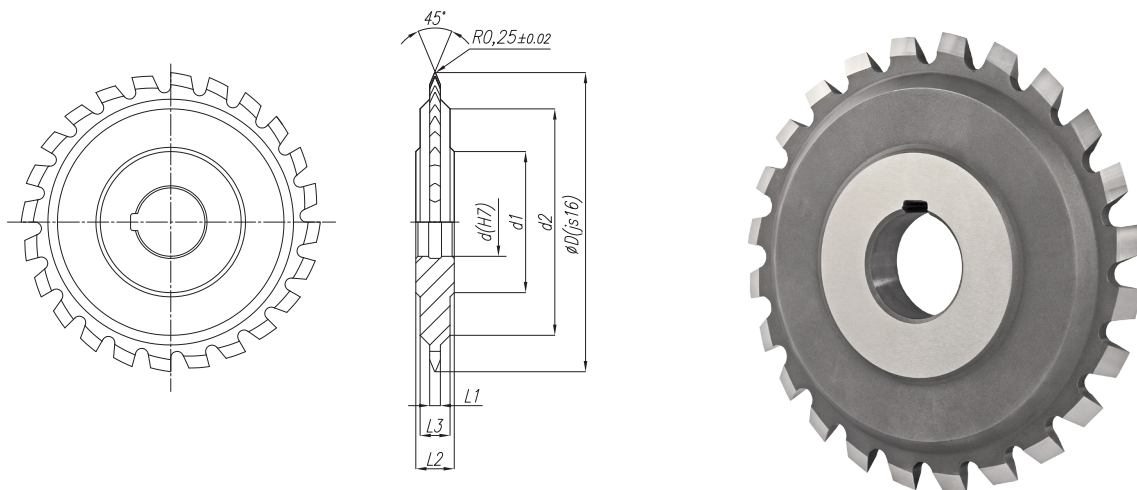

D (js16)	d (H7)	d1	d2	L1	L2	L3	z	HSS-E	
								Code No	0641-572-
135	32	66	101	5	18 ±0,1	14	24	050602	○
140	32	66	106	5	18 ±0,1	14	24	050704	○