

WERKZEUGAUFNAHMEN
ISO 7388-1
(ehemals DIN 69871)

TOOLHOLDERS
ISO 7388-1
(formerly DIN 69871)

PORTE-OUTILS
ISO 7388-1
(l'ancien DIN 69871)

ISO 7388-1

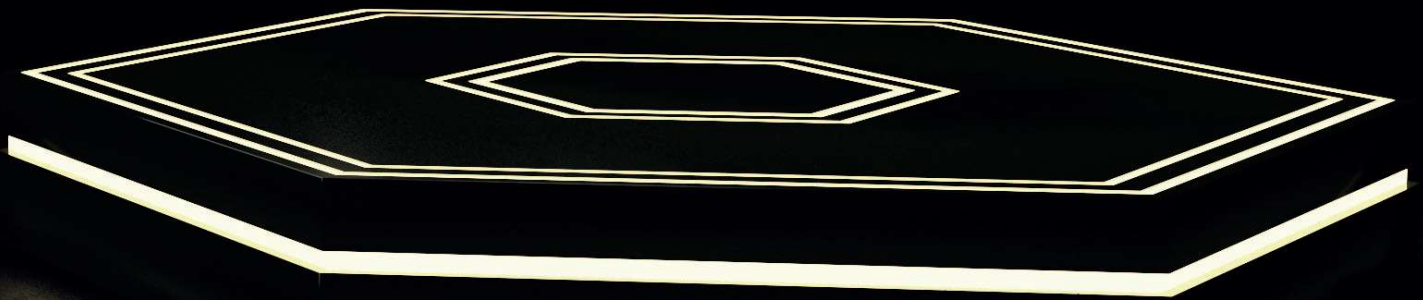



Werkzeugaufnahmen DIN ISO 7388-1 (ehemals DIN 69871)

Toolholders DIN ISO 7388-1 (formerly DIN 69871)

Porte-outils DIN ISO 7388-1 (l'ancien DIN 69871)

1

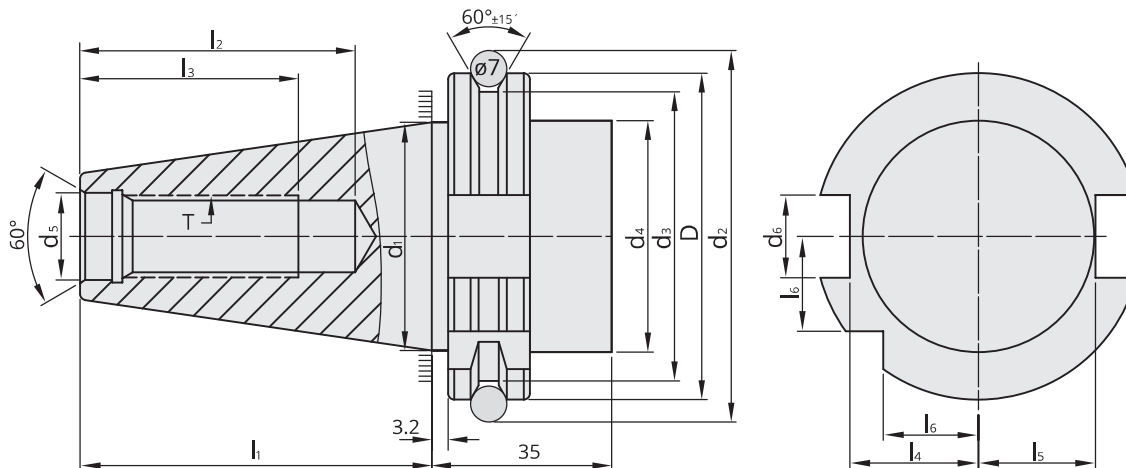

SK	D	d ₁	d ₂	d ₃	d ₄	d ₅	d ₆	d ₉	l ₁	l ₂	l ₃	l ₄	l ₅	l ₆	e ₁	e ₂	T
	⁰ / _{-0,1}		±0,05	⁰ / _{-0,5}	max	H7	H12		⁰ / _{-0,3}	min	min	⁰ / _{-0,4}	⁰ / _{-0,4}	⁰ / _{-0,3}	±0,1	max	
30	50,00	31,75	59,30	44,30	45	13	16,1	4	47,8	33,5	24	19	16,4	15	21	5	M12
40	63,55	44,45	72,30	56,25	50	17	16,1	4	68,4	42,5	32	25	22,8	18,5	27	5	M16
50	97,50	69,85	107,25	91,25	80	25	25,7	6	101,75	61,5	47	37,7	35,5	30	42	7	M24

Vorgewuchtet G 6,3 15.000 min⁻¹
Pre-balanced
Pré-équilibré

G 2,5 Feinwuchten gegen Aufpreis
G 2.5 Fine balancing at extra charge
G 2,5 Équilibrage de précision moyennant un supplément

Mit innerer Kühlmittelzufuhr über den Bund - Form AD/AF (ehemals AD/B)

With internal coolant through the collar - form AD/AF (formerly AD/B)

Avec arrosage interne par la collerette - forme AD/AF (anciennement AD/B)

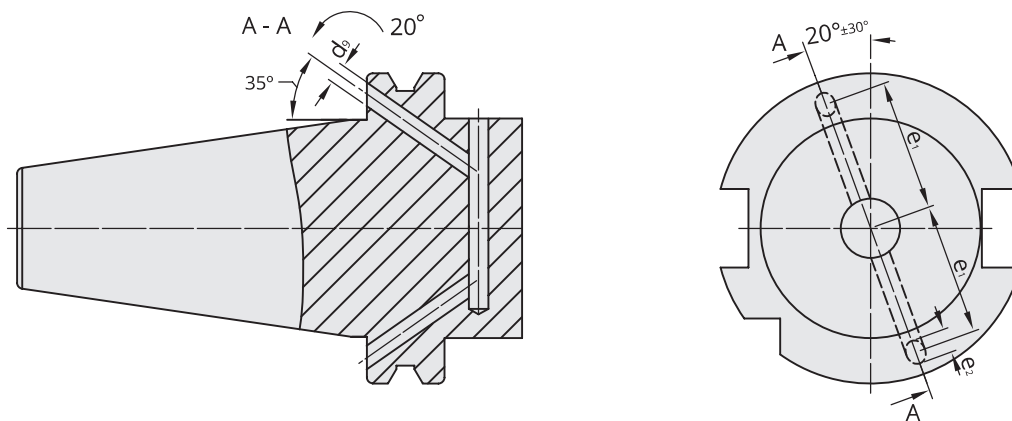

Werkstoff: Legierter Einsatzstahl mit einer Zugfestigkeit im Kern von min. 950 N / mm². Einsatzgehärtet HRC 60 ± 2 (HV 700 ± 50), Härtetiefe 0,8 mm ± 0,2 mm, brüniert und präzisionsgeschliffen.

Form AD/AF: Lieferung in Ausführung AD, Form AF (B) mit lösbaren Gewindestiften verschlossen.

Genauigkeit: Kegelwinkel - Toleranzqualität < AT 3 nach DIN 7187 und DIN 2080.

Material: Alloyed case-hardened steel, tensile core strength of min. 950 N / mm². Case hardened HRC 60 ± 2 (HV 700 ± 50), hardening depth 0.8 mm ± 0.2 mm, black-finished and precisely grinded.

Form AD/AF: Delivery in form AD, type AF (B) closed with releasable headless screws.

Accuracy: Quality of taper < AT 3 according to DIN 7187 and DIN 2080.

Matière: Acier de cémentation allié. Résistance à la traction dans le noyau d'au moins 950 N / mm². Cémenté et trempé HRC 60 ± 2 (HV 700 ± 50), profondeur de trempe 0,8 mm ± 0,2 mm, brunie et rectifiée avec précision.

Forme AD/AF: Livraison en forme AD, forme AF (B) fermée avec de vis sans tête amovibles.

Précision: Angle de cône - qualité de tolérance < AT 3 selon DIN 7187 et DIN 2080



Toolholders DIN ISO 7388-1 (formerly DIN 69871)

Porte-outils DIN ISO 7388-1 (l'ancien DIN 69871)



 16	 16	 16	 18
 18	 19	 19	 19
 20	 22	 23	 23
 24	 24	 26	 26
 26	 26	 27	 27
 28	 28	 29	 29
 29	 29	 30	 31
 32	 33	 33	 33
 33	 33	 33	 33



Werkzeugaufnahmen DIN ISO 7388-1 (ehemals DIN 69871)

Toolholders DIN ISO 7388-1 (formerly DIN 69871)

Porte-outils DIN ISO 7388-1 (l'ancien DIN 69871)

1



Spannfutter DIN 6391 für Spannzangen ISO 10897 (DIN 6388) System OZ
Collet chucks DIN 6391 for collets ISO 10897 (DIN 6388) OZ-system
 Mandrins à pinces DIN 6391 pour pinces ISO 10897 (DIN 6388) système OZ

ISO 7388-1 | Form AD/AF (AD/B) | $\leq 3\mu\text{m}$ | G2,5 25.000 min⁻¹ | RFID Chip | ISO 15488

Bestell-Nr. Order no. / Réf.	Abmessung Size / Dimension	Euro
302.01.16*	SK 30 - 2 / 16 - 60 OZ 16	75,00
302.01.25*	SK 30 - 2 / 25 - 80 OZ 25	76,00
403.01.16	SK 40 - 2 / 16 - 70 OZ 16	71,00
403.01.25	SK 40 - 2 / 25 - 70 OZ 25	72,00
403.01.32	SK 40 - 3 / 32 - 90 OZ 32	76,00
403.01.16.1	SK 40 - 2 / 16 - 100 OZ 16	86,00
403.01.25.1	SK 40 - 2 / 25 - 100 OZ 25	86,00
503.01.25	SK 50 - 2 / 25 - 70 OZ 25	103,00
503.01.32	SK 50 - 3 / 32 - 80 OZ 32	108,00
503.01.32.1	SK 50 - 3 / 32 - 100 OZ 32	125,00

* Form AD | * Form AD | * Forme AD



Hochleistungs-Kraftspannfutter System HKS
High Performance Milling Chuck HKS-system
 Mandrin de serrage à haute performance système HKS

ISO 7388-1 | Form AD/AF (AD/B) | $\leq 3\mu\text{m}$ | G6,3 15.000 min⁻¹ | RFID Chip | HKS

Bestell-Nr. Order no. / Référence	Abmessung Size / Dimension	Euro
403.64.20	SK 40 - 20 - 90	227,00
403.64.25	SK 40 - 25 - 105	233,00
403.64.32	SK 40 - 32 - 105	239,00
503.64.20	SK 50 - 20 - 90	306,00
503.64.25	SK 50 - 25 - 90	313,00
503.64.32	SK 50 - 32 - 90	318,00



Spannfutter für Spannzangen ISO 15488 (DIN 6499) System ER
Collet chucks for collets ISO 15488 (DIN 6499) ER-system
 Mandrins à pinces pour pinces ISO 15488 (DIN 6499) système ER

ISO 7388-1 | Form AD | $\leq 3\mu\text{m}$ | G2,5 25.000 min⁻¹ | RFID Chip | ISO 15488

Bestell-Nr. Order no. / Réf.	Abmessung Size / Dimension	Euro
302.02.10	SK 30 - 1 / 10 - 70 ER 16	62,00
302.02.13	SK 30 - 2 / 13 - 70 ER 20	62,00
302.02.16	SK 30 - 2 / 16 - 70 ER 25	62,00
302.02.20	SK 30 - 2 / 20 - 70 ER 32	64,00
302.02.26	SK 30 - 3 / 26 - 70 ER 40	67,00
302.02.10.1	SK 30 - 1 / 10 - 100 ER 16	68,00
302.02.13.1	SK 30 - 2 / 13 - 100 ER 20	76,00
302.02.16.1	SK 30 - 2 / 16 - 100 ER 25	76,00
302.02.20.1	SK 30 - 2 / 20 - 100 ER 32	76,00
402.02.10	SK 40 - 1 / 10 - 63 ER 16	52,00
402.02.13	SK 40 - 2 / 13 - 70 ER 20	52,00
402.02.16	SK 40 - 2 / 16 - 60 ER 25	52,00
402.02.20	SK 40 - 2 / 20 - 70 ER 32	54,00
402.02.26	SK 40 - 3 / 26 - 80 ER 40	57,00
402.02.10.1	SK 40 - 1 / 10 - 100 ER 16	58,00
402.02.13.1	SK 40 - 2 / 13 - 100 ER 20	65,00
402.02.16.1	SK 40 - 2 / 16 - 100 ER 25	65,00
402.02.20.1	SK 40 - 2 / 20 - 100 ER 32	65,00
402.02.26.1	SK 40 - 3 / 26 - 100 ER 40	74,00





Toolholders DIN ISO 7388-1 (formerly DIN 69871)

Porte-outils DIN ISO 7388-1 (l'ancien DIN 69871)



ISO 7388-1 Form AD/AF (AD/B) ≤ 3µm G2,5 25,000 min⁻¹ RFID Chip ISO 15488

ISO 7388-1 Form AD/AF (AD/B) ≤ 3µm G2,5 25,000 min⁻¹ RFID Chip ISO 15488

Bestell-Nr. Order no. / Réf.	Abmessung Size / Dimension	Euro
403.02.10	SK 40 - 1 / 10 - 63 ER 16	54,00
403.02.13	SK 40 - 2 / 13 - 70 ER 20	54,00
403.02.16	SK 40 - 2 / 16 - 60 ER 25	54,00
403.02.20	SK 40 - 2 / 20 - 70 ER 32	56,00
403.02.26	SK 40 - 3 / 26 - 80 ER 40	59,00
403.02.10.1	SK 40 - 1 / 10 - 100 ER 16	60,00
403.02.13.1	SK 40 - 2 / 13 - 100 ER 20	67,00
403.02.16.1	SK 40 - 2 / 16 - 100 ER 25	67,00
403.02.20.1	SK 40 - 2 / 20 - 100 ER 32	67,00
403.02.26.1	SK 40 - 3 / 26 - 100 ER 40	75,00
403.02.10.130	SK 40 - 1 / 10 - 130 ER 16	82,00
403.02.13.130	SK 40 - 2 / 13 - 130 ER 20	82,00
403.02.16.130	SK 40 - 2 / 16 - 130 ER 25	86,00
403.02.20.130	SK 40 - 2 / 20 - 130 ER 32	89,00
403.02.26.130	SK 40 - 3 / 26 - 130 ER 40	101,00
403.02.10.2	SK 40 - 1 / 10 - 160 ER 16	100,00
403.02.13.2	SK 40 - 2 / 13 - 160 ER 20	100,00
403.02.16.2	SK 40 - 2 / 16 - 160 ER 25	100,00
403.02.20.2	SK 40 - 2 / 20 - 160 ER 32	102,00
403.02.26.2	SK 40 - 3 / 26 - 160 ER 40	115,00
403.02.10.3	SK 40 - 1 / 10 - 200 ER 16	147,00
403.02.13.3	SK 40 - 2 / 13 - 200 ER 20	147,00
403.02.16.3	SK 40 - 2 / 16 - 200 ER 25	147,00
403.02.20.3	SK 40 - 2 / 20 - 200 ER 32	152,00
403.02.26.3	SK 40 - 3 / 26 - 200 ER 40	162,00

Bestell-Nr. Order no. / Réf.	Abmessung Size / Dimension	Euro
503.02.10	SK 50 - 1 / 10 - 70 ER 16	96,00
503.02.13	SK 50 - 2 / 13 - 70 ER 20	96,00
503.02.16	SK 50 - 2 / 16 - 60 ER 25	96,00
503.02.20	SK 50 - 2 / 20 - 70 ER 32	96,00
503.02.26	SK 50 - 3 / 26 - 80 ER 40	98,00
503.02.10.1	SK 50 - 1 / 10 - 100 ER 16	110,00
503.02.13.1	SK 50 - 2 / 13 - 100 ER 20	110,00
503.02.16.1	SK 50 - 2 / 16 - 100 ER 25	110,00
503.02.20.1	SK 50 - 2 / 20 - 100 ER 32	128,00
503.02.26.1	SK 50 - 3 / 26 - 100 ER 40	133,00
503.02.10.130	SK 50 - 1 / 10 - 130 ER 16	130,00
503.02.13.130	SK 50 - 2 / 13 - 130 ER 20	130,00
503.02.16.130	SK 50 - 2 / 16 - 130 ER 25	132,00
503.02.20.130	SK 50 - 2 / 20 - 130 ER 32	135,00
503.02.26.130	SK 50 - 3 / 26 - 130 ER 40	145,00
503.02.10.2	SK 50 - 1 / 10 - 160 ER 16	148,00
503.02.13.2	SK 50 - 2 / 13 - 160 ER 20	148,00
503.02.16.2	SK 50 - 2 / 16 - 160 ER 25	148,00
503.02.20.2	SK 50 - 2 / 20 - 160 ER 32	148,00
503.02.26.2	SK 50 - 3 / 26 - 160 ER 40	151,00
503.02.10.3	SK 50 - 1 / 10 - 200 ER 16	193,00
503.02.13.3	SK 50 - 2 / 13 - 200 ER 20	193,00
503.02.16.3	SK 50 - 2 / 16 - 200 ER 25	193,00
503.02.20.3	SK 50 - 2 / 20 - 200 ER 32	202,00
503.02.26.3	SK 50 - 3 / 26 - 200 ER 40	215,00

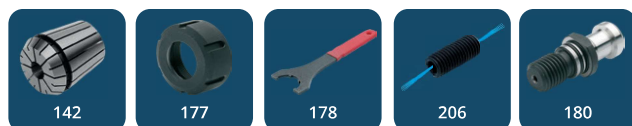



Werkzeugaufnahmen DIN ISO 7388-1 (ehemals DIN 69871)

Toolholders DIN ISO 7388-1 (formerly DIN 69871)

Porte-outils DIN ISO 7388-1 (l'ancien DIN 69871)

1



Spannfutter für Spannzangen
ISO 15488 (DIN 6499) System ER
Collet chucks for collets ISO 15488
(DIN 6499) ER-system
Mandrins à pinces pour pinces
ISO 15488 (DIN 6499) système ER



Bestell-Nr. Order no. / Réf.	Abmessung Size / Dimension	Euro
302.02.07*	SK 30 - 1 / 7 - 70 ER 11	102,00
302.02.07.1*	SK 30 - 1 / 7 - 100 ER 11	122,00
302.02.07.10*	SK 30 - 1 / 10 - 70 ER 16	102,00
302.02.07.10.1	SK 30 - 1 / 10 - 100 ER 16	122,00
403.02.07	SK 40 - 1 / 7 - 55 ER 11	92,00
403.02.07.1	SK 40 - 1 / 7 - 100 ER 11	110,00
403.02.07.2	SK 40 - 1 / 7 - 160 ER 11	126,00
403.02.07.10	SK 40 - 1 / 10 - 55 ER 16	92,00
403.02.07.10.1	SK 40 - 1 / 10 - 100 ER 16	110,00
403.02.07.10.2	SK 40 - 1 / 10 - 160 ER 16	126,00
403.02.07.13	SK 40 - 2 / 13 - 70 ER 20	110,00
403.02.07.13.1	SK 40 - 2 / 13 - 100 ER 20	120,00
403.02.07.13.2	SK 40 - 2 / 13 - 160 ER 20	141,00
403.02.07.16	SK 40 - 2 / 16 - 70 ER 25	110,00
403.02.07.16.1	SK 40 - 2 / 16 - 100 ER 25	120,00
403.02.07.16.2	SK 40 - 2 / 16 - 160 ER 25	141,00
503.02.07.10.1	SK 50 - 1 / 10 - 100 ER 16	162,00
503.02.07.10.2	SK 50 - 1 / 10 - 160 ER 16	197,00

Mit Minimutter | With mini nut | Avec écrous-mini

* Form AD | * Form AD | * Forme AD



Präzisions-Spannzangenfutter
ER für Spannzangen
ISO 15488 (DIN 6499) System ER
Precision collet chuck ER for collets
ISO 15488 (DIN 6499) ER-system
Mandrin à pinces ER de précision-
pour pinces ISO 15488 (DIN 6499)
système ER



Bestell-Nr. Order no. / Réf.	Abmessung Size / Dimension	Euro
402.P2.20.070	SK 40 - 2 / 20 - 70 ER 32	99,00
402.P2.20.100	SK 40 - 2 / 20 - 100 ER 32	108,00
402.P2.20.125	SK 40 - 2 / 20 - 125 ER 32	118,00
402.P2.20.150	SK 40 - 2 / 20 - 150 ER 32	128,00
402.P2.20.200	SK 40 - 2 / 20 - 200 ER 32	140,00
502.P2.20.070	SK 50 - 2 / 20 - 70 ER 32	134,00
502.P2.20.100	SK 50 - 2 / 20 - 100 ER 32	140,00
502.P2.20.125	SK 50 - 2 / 20 - 125 ER 32	150,00
502.P2.20.150	SK 50 - 2 / 20 - 150 ER 32	160,00
502.P2.20.200	SK 50 - 2 / 20 - 200 ER 32	170,00

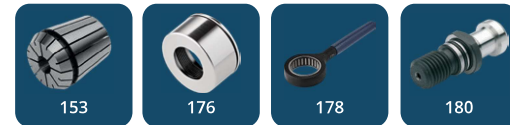

Gewuchtete Ausführung
Balanced type
Type équilibré

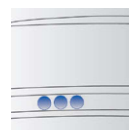

Bestell-Nr. Order no. / Réf.	Abmessung Size / Dimension	Euro
Wuchten auf G 2,5 von vorgewuchteten DOLFAMEX-Werkzeugen Balancing at G 2.5 of pre-balanced DOLFAMEX-tools Équilibrage sur G 2,5 d'outils DOLFAMEX pré-équilibrés		
W25	Ohne Wuchtprotokoll Without balancing report Sans protocole d'équilibrage	15,00
W25.2	Mit Wuchtprotokoll With balancing report Avec protocole d'équilibrage	19,00
Wuchten von nicht vorgewuchteten Werkzeugen Balancing of unbalanced tools Équilibrage d'outils non-équilibrés		
W25.1	Ohne Wuchtprotokoll Without balancing report Sans protocole d'équilibrage	28,00



Toolholders DIN ISO 7388-1 (formerly DIN 69871)

Porte-outils DIN ISO 7388-1 (l'ancien DIN 69871)



Spannfutter für Spannzangen System KPS
Collet chucks for collets KPS-system
 Mandrins à pinces pour pinces système KPS

ISO 7388-1 Form AD/AF (AD/B) $\leq 3\mu\text{m}$ G2,5 30.000 min⁻¹ RFID Chip KPS

Bestell-Nr. Order no. / Réf.	Abmessung Size / Dimension		Euro
302.03.10	SK 30 - 1 / 10 - 60	KPS 10	116,00
302.03.16	SK 30 - 4 / 16 - 60	KPS 16	133,00
302.03.10.1	SK 30 - 1 / 10 - 90	KPS 10	121,00
302.03.16.1	SK 30 - 4 / 16 - 90	KPS 16	143,00
402.03.10	SK 40 - 1 / 10 - 60	KPS 10	120,00
402.03.16	SK 40 - 4 / 16 - 60	KPS 16	122,00
402.03.10.1	SK 40 - 1 / 10 - 90	KPS 10	129,00
402.03.16.1	SK 40 - 4 / 16 - 90	KPS 16	131,00
402.03.10.2	SK 40 - 1 / 10 - 120	KPS 10	138,00
402.03.16.2	SK 40 - 4 / 16 - 120	KPS 16	140,00
402.03.10.3	SK 40 - 1 / 10 - 160	KPS 10	147,00
402.03.16.3	SK 40 - 4 / 16 - 160	KPS 16	151,00
502.03.10	SK 50 - 1 / 10 - 105	KPS 10	223,00
502.03.16	SK 50 - 4 / 16 - 105	KPS 16	227,00
502.03.10.1	SK 50 - 1 / 10 - 135	KPS 10	238,00
502.03.16.1	SK 50 - 4 / 16 - 135	KPS 16	247,00
502.03.10.2	SK 50 - 1 / 10 - 165	KPS 10	258,00
502.03.16.2	SK 50 - 4 / 16 - 165	KPS 16	267,00



Spannfutter für Spannzangen ISO 15488 (DIN 6499) System ER ohne Mitnehmernuten
Collet chucks for collets ISO 15488 (DIN 6499) ER-system without drive slots
 Mandrins à pinces pour pinces ISO 15488 (DIN 6499) système ER sans rainures d'entraînement

ISO 7388-1 Form AD $\leq 3\mu\text{m}$ G2,5 25.000 min⁻¹ ISO 15488

Bestell-Nr. Order no. / Réf.	Abmessung Size / Dimension	Euro
302.62.16	SK 30 - 2 / 16 - 50 ER 25	85,00
302.62.20	SK 30 - 2 / 20 - 50 ER 32	88,00
302.62.20.1	SK 30 - 2 / 20 - 57 ER 32	98,00
302.62.20.2	SK 30 - 2 / 20 - 63 ER 32	102,00
302.62.26	SK 30 - 3 / 26 - 60 ER 40	120,00
402.62.16	SK 40 - 2 / 16 - 50 ER 25	76,00
402.62.20	SK 40 - 2 / 20 - 50 ER 32	81,00
402.62.26	SK 40 - 3 / 26 - 63 ER 40	84,00



Spannfutter DIN 6391 für Spannzangen ISO 10897 (DIN 6388) System OZ ohne Mitnehmernuten

Collet chucks DIN 6391 for collets ISO 10897 (DIN 6388) OZ-system without drive slots

Mandrins à pinces ISO 10897 (DIN 6388) système OZ sans rainures d'entraînement



ISO 7388-1 Form AD $\leq 3\mu\text{m}$ G2,5 25.000 min⁻¹ ISO 10897

Bestell-Nr. Order no. / Réf.	Abmessung Size / Dimension	Euro
302.61.25	SK 30 - 2 / 25 - 71 OZ 25	184,00
402.61.25	SK 40 - 2 / 25 - 63 OZ 25	171,00





Werkzeugaufnahmen DIN ISO 7388-1 (ehemals DIN 69871)

Toolholders DIN ISO 7388-1 (formerly DIN 69871)

Porte-outils DIN ISO 7388-1 (l'ancien DIN 69871)

1



Fräseraufnahmen DIN 6359
für Zylinderschäfte DIN 1835-B
End mill holders DIN 6359
for end mills DIN 1835-B
Porte-fraises DIN 6359 pour queues
cylindriques DIN 1835-B



Bestell-Nr. Order no. / Référence	Abmessung Size / Dimension	Euro
302.04.06	SK 30 - 06 - 50	52,00
302.04.08	SK 30 - 08 - 50	47,00
302.04.10	SK 30 - 10 - 50	47,00
302.04.12	SK 30 - 12 - 50	47,00
302.04.14	SK 30 - 14 - 63	47,00
302.04.16	SK 30 - 16 - 63	47,00
302.04.18	SK 30 - 18 - 63	47,00
302.04.20	SK 30 - 20 - 70	47,00
402.04.06	SK 40 - 06 - 50	38,00
402.04.08	SK 40 - 08 - 50	36,00
402.04.10	SK 40 - 10 - 50	36,00
402.04.12	SK 40 - 12 - 50	36,00
402.04.14	SK 40 - 14 - 50	36,00
402.04.16	SK 40 - 16 - 63	36,00
402.04.18	SK 40 - 18 - 63	36,00
402.04.20	SK 40 - 20 - 63	36,00
402.04.25	SK 40 - 25 - 100	45,00
402.04.32	SK 40 - 32 - 100	48,00
402.04.06.1	SK 40 - 06 - 100	51,00
402.04.08.1	SK 40 - 08 - 100	48,00
402.04.10.1	SK 40 - 10 - 100	48,00
402.04.12.1	SK 40 - 12 - 100	48,00
402.04.14.1	SK 40 - 14 - 100	48,00
402.04.16.1	SK 40 - 16 - 100	48,00
402.04.18.1	SK 40 - 18 - 100	48,00
402.04.20.1	SK 40 - 20 - 100	48,00



Fräseraufnahmen DIN 6359
für Zylinderschäfte DIN 1835-B
End mill holders DIN 6359
for end mills DIN 1835-B
Porte-fraises DIN 6359 pour
queues cylindriques DIN 1835-B



Bestell-Nr. Order no. / Référence	Abmessung Size / Dimension	Euro
403.04.16.0	SK 40 - 16 - 35	54,00
403.04.20.0	SK 40 - 20 - 35	54,00
403.04.25.0	SK 40 - 25 - 35	60,00
403.04.32.0	SK 40 - 32 - 65	63,00
403.04.06	SK 40 - 06 - 50	44,00
403.04.08	SK 40 - 08 - 50	40,00
403.04.10	SK 40 - 10 - 50	40,00
403.04.12	SK 40 - 12 - 50	40,00
403.04.14	SK 40 - 14 - 50	40,00
403.04.16	SK 40 - 16 - 63	40,00
403.04.18	SK 40 - 18 - 63	40,00
403.04.20	SK 40 - 20 - 63	40,00
403.04.25	SK 40 - 25 - 100	54,00
403.04.32	SK 40 - 32 - 100	56,00
403.04.40	SK 40 - 40 - 120	66,00
403.04.06.1	SK 40 - 06 - 100	53,00
403.04.08.1	SK 40 - 08 - 100	50,00
403.04.10.1	SK 40 - 10 - 100	50,00
403.04.12.1	SK 40 - 12 - 100	50,00
403.04.14.1	SK 40 - 14 - 100	50,00
403.04.16.1	SK 40 - 16 - 100	50,00
403.04.18.1	SK 40 - 18 - 100	50,00
403.04.20.1	SK 40 - 20 - 100	50,00
403.04.06.130	SK 40 - 06 - 130	79,00
403.04.08.130	SK 40 - 08 - 130	73,00
403.04.10.130	SK 40 - 10 - 130	73,00
403.04.12.130	SK 40 - 12 - 130	73,00
403.04.14.130	SK 40 - 14 - 130	73,00
403.04.16.130	SK 40 - 16 - 130	73,00
403.04.18.130	SK 40 - 18 - 130	73,00
403.04.20.130	SK 40 - 20 - 130	73,00
403.04.06.2	SK 40 - 06 - 160	86,00
403.04.08.2	SK 40 - 08 - 160	81,00
403.04.10.2	SK 40 - 10 - 160	81,00
403.04.12.2	SK 40 - 12 - 160	81,00
403.04.14.2	SK 40 - 14 - 160	81,00
403.04.16.2	SK 40 - 16 - 160	81,00
403.04.18.2	SK 40 - 18 - 160	81,00
403.04.20.2	SK 40 - 20 - 160	81,00
403.04.25.2	SK 40 - 25 - 160	93,00
403.04.32.2	SK 40 - 32 - 160	100,00
403.04.40.2	SK 40 - 40 - 160	117,00



Toolholders DIN ISO 7388-1 (formerly DIN 69871)

Porte-outils DIN ISO 7388-1 (l'ancien DIN 69871)



Fräseraufnahmen DIN 6359
für Zylinderschäfte DIN 1835-B
End mill holders DIN 6359
for end mills DIN 1835-B
Porte-fraises DIN 6359 pour
queues cylindriques DIN 1835-B

ISO 7388-1	Form AD/AF (AD/B)	≤ 3µm	G2,5 25,000 min ⁻¹	RFID Chip	DIN 1835-B
------------	-------------------	-------	-------------------------------	-----------	------------

Bestell-Nr. Order no. / Référence	Abmessung Size / Dimension	Euro
503.04.06	SK 50 - 06 - 63	70,00
503.04.08	SK 50 - 08 - 63	67,00
503.04.10	SK 50 - 10 - 63	67,00
503.04.12	SK 50 - 12 - 63	67,00
503.04.14	SK 50 - 14 - 63	67,00
503.04.16	SK 50 - 16 - 63	67,00
503.04.18	SK 50 - 18 - 63	67,00
503.04.20	SK 50 - 20 - 63	67,00
503.04.25	SK 50 - 25 - 80	75,00
503.04.32	SK 50 - 32 - 100	80,00
503.04.40	SK 50 - 40 - 100	86,00
503.04.50	SK 50 - 50 - 120	215,00
503.04.06.1	SK 50 - 06 - 100	83,00
503.04.08.1	SK 50 - 08 - 100	80,00
503.04.10.1	SK 50 - 10 - 100	80,00
503.04.12.1	SK 50 - 12 - 100	80,00
503.04.14.1	SK 50 - 14 - 100	80,00
503.04.16.1	SK 50 - 16 - 100	80,00
503.04.18.1	SK 50 - 18 - 100	80,00
503.04.20.1	SK 50 - 20 - 100	80,00
503.04.25.1	SK 50 - 25 - 120	96,00
503.04.06.130	SK 50 - 06 - 130	108,00
503.04.08.130	SK 50 - 08 - 130	102,00
503.04.10.130	SK 50 - 10 - 130	102,00
503.04.12.130	SK 50 - 12 - 130	102,00
503.04.14.130	SK 50 - 14 - 130	102,00
503.04.16.130	SK 50 - 16 - 130	102,00
503.04.18.130	SK 50 - 18 - 130	102,00
503.04.20.130	SK 50 - 20 - 130	102,00

503.04.06.2	SK 50 - 06 - 160	133,00
503.04.08.2	SK 50 - 08 - 160	130,00
503.04.10.2	SK 50 - 10 - 160	130,00
503.04.12.2	SK 50 - 12 - 160	130,00
503.04.14.2	SK 50 - 14 - 160	130,00
503.04.16.2	SK 50 - 16 - 160	130,00
503.04.18.2	SK 50 - 18 - 160	130,00
503.04.20.2	SK 50 - 20 - 160	130,00
503.04.25.2	SK 50 - 25 - 160	140,00
503.04.32.2	SK 50 - 32 - 160	145,00
503.04.40.2	SK 50 - 40 - 160	150,00



Fräseraufnahmen DIN 6359
für Zylinderschäfte DIN 1835-B
End mill holders DIN 6359
for end mills DIN 1835-B
Porte-fraises DIN 6359 pour
queues cylindriques DIN 1835-B

ISO 7388-1	Form AD/AF (AD/B)	≤ 3µm	G2,5 25,000 min ⁻¹	RFID Chip	DIN 1835-B
------------	-------------------	-------	-------------------------------	-----------	------------

Bestell-Nr. Order no. / Référence	Abmessung Size / Dimension	Euro
503.04.06.3	SK 50 - 06 - 200	231,00
503.04.08.3	SK 50 - 08 - 200	228,00
503.04.10.3	SK 50 - 10 - 200	228,00
503.04.12.3	SK 50 - 12 - 200	228,00
503.04.14.3	SK 50 - 14 - 200	228,00
503.04.16.3	SK 50 - 16 - 200	228,00
503.04.18.3	SK 50 - 18 - 200	228,00
503.04.20.3	SK 50 - 20 - 200	228,00
503.04.25.3	SK 50 - 25 - 200	239,00
503.04.32.3	SK 50 - 32 - 200	245,00
503.04.40.3	SK 50 - 40 - 200	250,00



Nachträgliches Erodieren
von 2 Kühlkanalbohrungen
Supplementary eroding of 2
cooling channels
Éroder supplémentaire de 2
canaux d'arrosage

Bestell-Nr. Order no. / Référence	Euro
U.KKB	42,00





Werkzeugaufnahmen DIN ISO 7388-1 (ehemals DIN 69871)

Toolholders DIN ISO 7388-1 (formerly DIN 69871)

Porte-outils DIN ISO 7388-1 (l'ancien DIN 69871)

1



Fräseraufnahmen DIN 6359
mit Kühlkanälen
für Zylinderschäfte DIN 1835-B
*End mill holders DIN 6359
with coolant channels
for end mills DIN 1835-B*
Porte-fraises DIN 6359
avec canaux d'arrosage pour
queues cylindriques DIN 1835-B



Bestell-Nr. Order no. / Référence	Abmessung Size / Dimension	Euro
403.04.06.K	SK 40 - 06 - 50	57,00
403.04.08.K	SK 40 - 08 - 50	55,00
403.04.10.K	SK 40 - 10 - 50	55,00
403.04.12.K	SK 40 - 12 - 50	55,00
403.04.14.K	SK 40 - 14 - 50	55,00
403.04.16.K	SK 40 - 16 - 63	55,00
403.04.18.K	SK 40 - 18 - 63	55,00
403.04.20.K	SK 40 - 20 - 63	55,00
403.04.25.K	SK 40 - 25 - 100	73,00
403.04.32.K	SK 40 - 32 - 100	75,00
403.04.40.K	SK 40 - 40 - 120	82,00

403.04.06.1.K	SK 40 - 06 - 100	69,00
403.04.08.1.K	SK 40 - 08 - 100	66,00
403.04.10.1.K	SK 40 - 10 - 100	66,00
403.04.12.1.K	SK 40 - 12 - 100	66,00
403.04.14.1.K	SK 40 - 14 - 100	66,00
403.04.16.1.K	SK 40 - 16 - 100	66,00
403.04.18.1.K	SK 40 - 18 - 100	66,00
403.04.20.1.K	SK 40 - 20 - 100	66,00

403.04.06.130.K	SK 40 - 06 - 130	104,00
403.04.08.130.K	SK 40 - 08 - 130	98,00
403.04.10.130.K	SK 40 - 10 - 130	98,00
403.04.12.130.K	SK 40 - 12 - 130	98,00
403.04.14.130.K	SK 40 - 14 - 130	98,00
403.04.16.130.K	SK 40 - 16 - 130	98,00
403.04.18.130.K	SK 40 - 18 - 130	98,00
403.04.20.130.K	SK 40 - 20 - 130	98,00

403.04.06.2.K	SK 40 - 06 - 160	136,00
403.04.08.2.K	SK 40 - 08 - 160	130,00
403.04.10.2.K	SK 40 - 10 - 160	130,00
403.04.12.2.K	SK 40 - 12 - 160	130,00
403.04.14.2.K	SK 40 - 14 - 160	130,00
403.04.16.2.K	SK 40 - 16 - 160	130,00
403.04.18.2.K	SK 40 - 18 - 160	130,00
403.04.20.2.K	SK 40 - 20 - 160	130,00



Fräseraufnahmen DIN 6359
mit Kühlkanälen
für Zylinderschäfte DIN 1835-B
*End mill holders DIN 6359
with coolant channels
for end mills DIN 1835-B*
Porte-fraises DIN 6359
avec canaux d'arrosage pour
queues cylindriques DIN 1835-B



Bestell-Nr. Order no. / Référence	Abmessung Size / Dimension	Euro
503.04.06.K	SK 50 - 06 - 63	91,00
503.04.08.K	SK 50 - 08 - 63	87,00
503.04.10.K	SK 50 - 10 - 63	87,00
503.04.12.K	SK 50 - 12 - 63	87,00
503.04.14.K	SK 50 - 14 - 63	87,00
503.04.16.K	SK 50 - 16 - 63	87,00
503.04.18.K	SK 50 - 18 - 63	87,00
503.04.20.K	SK 50 - 20 - 63	87,00
503.04.25.K	SK 50 - 25 - 80	99,00
503.04.32.K	SK 50 - 32 - 100	101,00
503.04.40.K	SK 50 - 40 - 100	106,00

503.04.06.1.K	SK 50 - 06 - 100	110,00
503.04.08.1.K	SK 50 - 08 - 100	110,00
503.04.10.1.K	SK 50 - 10 - 100	110,00
503.04.12.1.K	SK 50 - 12 - 100	110,00
503.04.14.1.K	SK 50 - 14 - 100	110,00
503.04.16.1.K	SK 50 - 16 - 100	110,00
503.04.18.1.K	SK 50 - 18 - 100	110,00
503.04.20.1.K	SK 50 - 20 - 100	110,00

503.04.06.130.K	SK 50 - 06 - 130	152,00
503.04.08.130.K	SK 50 - 08 - 130	142,00
503.04.10.130.K	SK 50 - 10 - 130	142,00
503.04.12.130.K	SK 50 - 12 - 130	142,00
503.04.14.130.K	SK 50 - 14 - 130	142,00
503.04.16.130.K	SK 50 - 16 - 130	142,00
503.04.18.130.K	SK 50 - 18 - 130	142,00
503.04.20.130.K	SK 50 - 20 - 130	142,00
503.04.25.130.K	SK 50 - 25 - 130	147,00
503.04.32.130.K	SK 50 - 32 - 130	158,00
503.04.40.130.K	SK 50 - 40 - 130	168,00

503.04.06.2.K	SK 50 - 06 - 160	174,00
503.04.08.2.K	SK 50 - 08 - 160	167,00
503.04.10.2.K	SK 50 - 10 - 160	167,00
503.04.12.2.K	SK 50 - 12 - 160	167,00
503.04.14.2.K	SK 50 - 14 - 160	167,00
503.04.16.2.K	SK 50 - 16 - 160	167,00
503.04.18.2.K	SK 50 - 18 - 160	167,00
503.04.20.2.K	SK 50 - 20 - 160	167,00
503.04.25.2.K	SK 50 - 25 - 160	174,00
503.04.32.2.K	SK 50 - 32 - 160	184,00
503.04.40.2.K	SK 50 - 40 - 160	194,00



Toolholders DIN ISO 7388-1 (formerly DIN 69871)

Porte-outils DIN ISO 7388-1 (l'ancien DIN 69871)



Fräseraufnahmen DIN 6359
für Zylinderschäfte DIN 1835-E
Whistle Notch
End mill holders DIN 6359 for
end mills DIN 1835-E Whistle Notch
Porte-fraises DIN 6359 pour
queues cylindriques DIN 1835-E
Whistle Notch



Bestell-Nr. Order no. / Référence	Abmessung Size / Dimension	Euro
403.05.06	SK 40 - 06 - 50	55,00
403.05.08	SK 40 - 08 - 50	51,00
403.05.10	SK 40 - 10 - 50	51,00
403.05.12	SK 40 - 12 - 50	51,00
403.05.14	SK 40 - 14 - 50	51,00
403.05.16	SK 40 - 16 - 63	51,00
403.05.18	SK 40 - 18 - 63	51,00
403.05.20	SK 40 - 20 - 63	51,00
403.05.25	SK 40 - 25 - 100	59,00
403.05.32	SK 40 - 32 - 100	64,00
403.05.40	SK 40 - 40 - 120	75,00
503.05.06	SK 50 - 06 - 63	79,00
503.05.08	SK 50 - 08 - 63	76,00
503.05.10	SK 50 - 10 - 63	76,00
503.05.12	SK 50 - 12 - 63	76,00
503.05.14	SK 50 - 14 - 63	76,00
503.05.16	SK 50 - 16 - 63	76,00
503.05.18	SK 50 - 18 - 63	76,00
503.05.20	SK 50 - 20 - 63	76,00
503.05.25	SK 50 - 25 - 80	84,00
503.05.32	SK 50 - 32 - 100	89,00
503.05.40	SK 50 - 40 - 100	96,00



Zwischenhülsen für MK
mit Austreiblappen DIN 6383
Adaptor sleeves for MT
with tang DIN 6383
Douilles de réduction pour CM
à tenon DIN 6383



Bestell-Nr. Order no. / Référence	Abmessung Size / Dimension	Euro
403.07.01	SK 40 - 1 - 50	40,00
403.07.02	SK 40 - 2 - 50	40,00
403.07.03	SK 40 - 3 - 70	40,00
403.07.04	SK 40 - 4 - 95	45,00
503.07.01	SK 50 - 1 - 45	65,00
503.07.02	SK 50 - 2 - 60	65,00
503.07.03	SK 50 - 3 - 65	65,00
503.07.04	SK 50 - 4 - 95	65,00
503.07.05	SK 50 - 5 - 105	71,00



Zwischenhülsen für MK
mit Anzugsgewinde DIN 6364
Adaptor sleeves for MT
with drawbar thread DIN 6364
Douilles de réduction pour CM
avec filetage DIN 6364



Bestell-Nr. Order no. / Référence	Abmessung Size / Dimension	Euro
402.08.01	SK 40 - 1 - 50	71,00
402.08.02	SK 40 - 2 - 50	71,00
402.08.03	SK 40 - 3 - 70	71,00
402.08.04	SK 40 - 4 - 95	76,00
402.08.04A*	SK 40 - 4 - 110	83,00
502.08.01	SK 50 - 1 - 45	96,00
502.08.02	SK 50 - 2 - 60	96,00
502.08.03	SK 50 - 3 - 65	96,00
502.08.04	SK 50 - 4 - 70	103,00
502.08.04A*	SK 50 - 4 - 85	110,00
502.08.05	SK 50 - 5 - 100	106,00
502.08.05A*	SK 50 - 5 - 118	119,00

* Mit Mitnahmeausfräsung nach DIN 2201
* With drive flats according to DIN 2201
* Avec des fraises d'entraînement suivant DIN 2201



Zwischenhülsen für MK
mit Austreiblappen DIN 6383
Adaptor sleeves for MT
with tang DIN 6383
Douilles de réduction pour CM
à tenon DIN 6383



Bestell-Nr. Order no. / Référence	Abmessung Size / Dimension	Euro
302.07.01	SK 30 - 1 - 50	47,00
302.07.02	SK 30 - 2 - 60	47,00
302.07.03	SK 30 - 3 - 80	47,00
402.07.01	SK 40 - 1 - 50	38,00
402.07.02	SK 40 - 2 - 50	38,00
402.07.03	SK 40 - 3 - 70	38,00
402.07.04	SK 40 - 4 - 95	41,00
402.07.02.1	SK 40 - 2 - 117	75,00
402.07.03.1	SK 40 - 3 - 133	75,00
402.07.04.1	SK 40 - 4 - 156	83,00
502.07.02.1	SK 50 - 2 - 117	143,00
502.07.03.1	SK 50 - 3 - 137	143,00
502.07.04.1	SK 50 - 4 - 167	157,00
502.07.05.1	SK 50 - 5 - 197	166,00



Werkzeugaufnahmen DIN ISO 7388-1 (ehemals DIN 69871)

Toolholders DIN ISO 7388-1 (formerly DIN 69871)

Porte-outils DIN ISO 7388-1 (l'ancien DIN 69871)

1



**Kombi-Aufsteckfräserdorne
DIN 6358**
Combi shell mill holders DIN 6358
Porte-fraises à double usage
DIN 6358



Bestell-Nr. <i>Order no. / Référence</i>	Abmessung <i>Size / Dimension</i>	Euro
302.10.16*	SK 30 - 16 - 50	60,00
302.10.22*	SK 30 - 22 - 50	61,00
302.10.27*	SK 30 - 27 - 55	61,00
302.10.32*	SK 30 - 32 - 60	65,00
403.10.16	SK 40 - 16 - 55	56,00
403.10.22	SK 40 - 22 - 55	57,00
403.10.27	SK 40 - 27 - 55	57,00
403.10.32	SK 40 - 32 - 60	61,00
403.10.40	SK 40 - 40 - 60	69,00
403.10.16.1	SK 40 - 16 - 100	66,00
403.10.22.1	SK 40 - 22 - 100	69,00
403.10.27.1	SK 40 - 27 - 100	70,00
403.10.32.1	SK 40 - 32 - 100	73,00
403.10.40.1	SK 40 - 40 - 100	81,00
403.10.16.2	SK 40 - 16 - 160	106,00
403.10.22.2	SK 40 - 22 - 160	111,00
403.10.27.2	SK 40 - 27 - 160	115,00
403.10.32.2	SK 40 - 32 - 160	119,00
403.10.40.2	SK 40 - 40 - 160	128,00
503.10.16	SK 50 - 16 - 55	79,00
503.10.22	SK 50 - 22 - 55	79,00
503.10.27	SK 50 - 27 - 55	80,00
503.10.32	SK 50 - 32 - 55	83,00
503.10.40	SK 50 - 40 - 55	89,00
503.10.16.1	SK 50 - 16 - 100	91,00
503.10.22.1	SK 50 - 22 - 100	91,00
503.10.27.1	SK 50 - 27 - 100	92,00
503.10.32.1	SK 50 - 32 - 100	94,00
503.10.40.1	SK 50 - 40 - 100	102,00
503.10.16.2	SK 50 - 16 - 160	157,00
503.10.22.2	SK 50 - 22 - 160	161,00
503.10.27.2	SK 50 - 27 - 160	170,00
503.10.32.2	SK 50 - 32 - 160	175,00
503.10.40.2	SK 50 - 40 - 160	188,00

* Form AD | * Form AD | * Forme AD



**Quernut-Aufsteckfräserdorne
DIN 6357 mit vergrößerter
Anlagefläche und Kühlkanal-
bohrungen an der Stirnseite**
*Shell mill holders DIN 6357 with
enlarged contact face and coolant
exit bores on the end face*
Porte-fraises à trou lisse DIN 6357
avec face de contact élargie
et conduits pour l'arrosage frontal



Bestell-Nr. <i>Order no. / Référence</i>	Abmessung <i>Size / Dimension</i>	Euro
302.11.16	SK 30 - 16 - 40	64,00
302.11.22	SK 30 - 22 - 40	64,00
302.11.27	SK 30 - 27 - 40	65,00
302.11.32	SK 30 - 32 - 50	68,00
402.11.16	SK 40 - 16 - 35	54,00
402.11.22	SK 40 - 22 - 35	54,00
402.11.27	SK 40 - 27 - 40	55,00
402.11.32	SK 40 - 32 - 50	58,00
402.11.40	SK 40 - 40 - 50	72,00

SK 30 ohne Kühlkanalbohrungen an der Stirnseite *SK 30 without coolant exit bores on the end face* SK 30 sans alésages pour l'arrosage frontal





Toolholders DIN ISO 7388-1 (formerly DIN 69871)

Porte-outils DIN ISO 7388-1 (l'ancien DIN 69871)



Quernut-Aufsteckfräserdorne
DIN 6357 mit vergrößerter
Anlagefläche und Kühlkanal-
bohrungen an der Stirnseite
*Shell mill holders DIN 6357 with
enlarged contact face and coolant
exit bores on the end face*
Porte-fraises à trou lisse DIN 6357
avec face de contact élargie
et conduits pour l'arrosage frontal



Bestell-Nr. Order no. / Référence	Abmessung Size / Dimension	Euro
403.11.16	SK 40 - 16 - 35	56,00
403.11.22	SK 40 - 22 - 35	56,00
403.11.27	SK 40 - 27 - 40	57,00
403.11.32	SK 40 - 32 - 50	60,00
403.11.40	SK 40 - 40 - 50	74,00
403.11.16.1	SK 40 - 16 - 100	69,00
403.11.22.1	SK 40 - 22 - 100	69,00
403.11.27.1	SK 40 - 27 - 100	70,00
403.11.32.1	SK 40 - 32 - 100	75,00
403.11.40.1	SK 40 - 40 - 100	88,00
403.11.16.130	SK 40 - 16 - 130	108,00
403.11.22.130	SK 40 - 22 - 130	108,00
403.11.27.130	SK 40 - 27 - 130	108,00
403.11.32.130	SK 40 - 32 - 130	117,00
403.11.40.130	SK 40 - 40 - 130	126,00
403.11.16.2	SK 40 - 16 - 160	109,00
403.11.22.2	SK 40 - 22 - 160	110,00
403.11.27.2	SK 40 - 27 - 160	113,00
403.11.32.2	SK 40 - 32 - 160	119,00
403.11.40.2	SK 40 - 40 - 160	132,00



Quernut-Aufsteckfräserdorne
DIN 6357 mit vergrößerter
Anlagefläche und Kühlkanal-
bohrungen an der Stirnseite
*Shell mill holders DIN 6357 with
enlarged contact face and coolant
exit bores on the end face*
Porte-fraises à trou lisse DIN 6357
avec face de contact élargie
et conduits pour l'arrosage frontal



Bestell-Nr. Order no. / Référence	Abmessung Size / Dimension	Euro
503.11.16	SK 50 - 16 - 45	83,00
503.11.22	SK 50 - 22 - 35	83,00
503.11.27	SK 50 - 27 - 40	83,00
503.11.32	SK 50 - 32 - 50	87,00
503.11.40	SK 50 - 40 - 50	99,00
503.11.60	SK 50 - 60 - 70	148,00
503.11.16.1	SK 50 - 16 - 100	93,00
503.11.22.1	SK 50 - 22 - 100	93,00
503.11.27.1	SK 50 - 27 - 100	93,00
503.11.32.1	SK 50 - 32 - 100	99,00
503.11.40.1	SK 50 - 40 - 100	114,00
503.11.16.130	SK 50 - 16 - 130	117,00
503.11.22.130	SK 50 - 22 - 130	117,00
503.11.27.130	SK 50 - 27 - 130	120,00
503.11.32.130	SK 50 - 32 - 130	133,00
503.11.40.130	SK 50 - 40 - 130	149,00
503.11.16.2	SK 50 - 16 - 160	146,00
503.11.22.2	SK 50 - 22 - 160	146,00
503.11.27.2	SK 50 - 27 - 160	147,00
503.11.32.2	SK 50 - 32 - 160	152,00
503.11.40.2	SK 50 - 40 - 160	165,00
503.11.16.3	SK 50 - 16 - 200	209,00
503.11.22.3	SK 50 - 22 - 200	209,00
503.11.27.3	SK 50 - 27 - 200	216,00
503.11.32.3	SK 50 - 32 - 200	221,00
503.11.40.3	SK 50 - 40 - 200	239,00





Werkzeugaufnahmen DIN ISO 7388-1 (ehemals DIN 69871)

Toolholders DIN ISO 7388-1 (formerly DIN 69871)

Porte-outils DIN ISO 7388-1 (l'ancien DIN 69871)

1



Kontrolldorne
Test arbors
Mandrins de contrôle



Bestell-Nr. Order no. / Référence	Abmessung Size / Dimension	Euro
302.18.32	SK 30 - 32 - 300	350,00
402.18.40	SK 40 - 40 - 302	336,00
502.18.50	SK 50 - 50 - 300	506,00



Holzkasten für Kontrolldorne
Wooden box for test arbors
Coffret en bois pour mandrins de contrôle

Bestell-Nr. Order no. / Référence	Abmessung Size / Dimension	Euro
701.18	460 x 130 x 115	96,00



Bohrstangenrohlinge
Boring bar blanks
Barres d'alésage



Bestell-Nr. Order no. / Référence	Abmessung Size / Dimension	Euro
302.17.40	SK 30 - 40,5 - 160	131,00
402.17.63	SK 40 - 63 - 250	132,00
502.17.97	SK 50 - 97 - 315	220,00



Zwischenhülsen für SK-Aufnahmen
Adaptor sleeves for ISO-toolholders
Douilles de réduction pour porte-outils ISO/SA



Bestell-Nr. Order no. / Référence	Abmessung Size / Dimension	Euro
402.09.30	SK 40 - SK 30 - 50	104,00
402.09.40	SK 40 - SK 40 - 100	104,00
502.09.40	SK 50 - SK 40 - 70	142,00
502.09.50	SK 50 - SK 50 - 120	163,00



Reduzierhülse für PSK-Schaft
Reducing adapter for PSK-shank
Douille de réduction pour queues PSK



Bestell-Nr. Order no. / Référence	Abmessung Size / Dimension	Euro
402.09.C3	SK 40 - PSK 32 - 30	315,00
402.09.C4	SK 40 - PSK 40 - 40	318,00
402.09.C5	SK 40 - PSK 50 - 50	321,00
402.09.C6	SK 40 - PSK 63 - 90	324,00



Toolholders DIN ISO 7388-1 (formerly DIN 69871)

Porte-outils DIN ISO 7388-1 (l'ancien DIN 69871)



Fräsaufnahme für Einschraubfräser
Milling arbors for screw-in cutters
Porte-fraises pour fraises à queue fileté



Bestell-Nr. Order no. / Référence	Abmessung Size / Dimension	Euro
403.06.06	SK 40 - M6 - 44	93,00
403.06.06.1	SK 40 - M6 - 69	105,00
403.06.06.2	SK 40 - M6 - 94	116,00
403.06.08	SK 40 - M8 - 44	93,00
403.06.08.1	SK 40 - M8 - 69	105,00
403.06.08.2	SK 40 - M8 - 94	116,00
403.06.08.3	SK 40 - M8 - 119	130,00
403.06.10.0	SK 40 - M10 - 24	88,00
403.06.10	SK 40 - M10 - 44	93,00
403.06.10.1	SK 40 - M10 - 69	100,00
403.06.10.2	SK 40 - M10 - 94	116,00
403.06.10.3	SK 40 - M10 - 119	133,00
403.06.10.5	SK 40 - M10 - 169	160,00
403.06.12.0	SK 40 - M12 - 24	88,00
403.06.12	SK 40 - M12 - 44	93,00
403.06.12.1	SK 40 - M12 - 69	100,00
403.06.12.2	SK 40 - M12 - 94	116,00
403.06.12.3	SK 40 - M12 - 119	133,00
403.06.12.5	SK 40 - M12 - 169	160,00
403.06.16.0	SK 40 - M16 - 24	89,00
403.06.16	SK 40 - M16 - 44	93,00
403.06.16.1	SK 40 - M16 - 69	105,00
403.06.16.2	SK 40 - M16 - 94	116,00
403.06.16.3	SK 40 - M16 - 119	133,00
403.06.16.5	SK 40 - M16 - 169	160,00
503.06.08.1	SK 50 - M8 - 69	132,00
503.06.08.3	SK 50 - M8 - 119	163,00
503.06.08.5	SK 50 - M8 - 169	191,00
503.06.10.1	SK 50 - M10 - 69	132,00
503.06.10.3	SK 50 - M10 - 119	163,00
503.06.10.5	SK 50 - M10 - 169	191,00
503.06.12.1	SK 50 - M12 - 69	132,00
503.06.12.3	SK 50 - M12 - 119	163,00
503.06.12.5	SK 50 - M12 - 169	191,00
503.06.16.1	SK 50 - M16 - 69	132,00
503.06.16.3	SK 50 - M16 - 119	163,00
503.06.16.5	SK 50 - M16 - 169	191,00



Bohrerhalter für Wendeplattenbohrer Form E1
Boring holders for drills with indexable inserts form E1
Portes forets pour forets à plaquettes réversibles forme E1



Bestell-Nr. Order no. / Référence	Abmessung Size / Dimension	Euro
403.51.20	SK 40 - 20 - 65	66,00
403.51.25	SK 40 - 25 - 70	66,00
403.51.32	SK 40 - 32 - 75	66,00
503.51.20	SK 50 - 20 - 70	107,00
503.51.25	SK 50 - 25 - 70	107,00
503.51.32	SK 50 - 32 - 70	107,00
503.51.40	SK 50 - 40 - 80	107,00

Gewuchtete Ausführung
Balanced type
Type équilibré



Bestell-Nr. Order no. / Réf.	Abmessung Size / Dimension	Euro
Wuchten auf G 2,5 von vorgewuchteten DOLFAMEX-Werkzeugen Balancing at G 2.5 of pre-balanced DOLFAMEX-tools Équilibrage sur G 2,5 d'outils DOLFAMEX pré-équilibrés		
W25	Ohne Wuchtprotokoll Without balancing report Sans protocole d'équilibrage	15,00
W25.2	Mit Wuchtprotokoll With balancing report Avec protocole d'équilibrage	19,00
Wuchten von nicht vorgewuchteten Werkzeugen Balancing of unbalanced tools Équilibrage d'outils non-équilibrés		
W25.1	Ohne Wuchtprotokoll Without balancing report Sans protocole d'équilibrage	28,00



Werkzeugaufnahmen DIN ISO 7388-1 (ehemals DIN 69871)

Toolholders DIN ISO 7388-1 (formerly DIN 69871)

Porte-outils DIN ISO 7388-1 (l'ancien DIN 69871)

1



**CNC-Bohrfutter
für Rechts- und Linkslauf**
CNC-Drill chucks for clockwise
and counter clockwise rotation
Mandrins de perçage CNC
pour rotation droite-gauche



Bestell-Nr. Order no. / Référence	Abmessung Size / Dimension	Euro
302.15.08	SK 30 - 0,5/8 - 70	328,00
302.15.13	SK 30 - 1,0/13 - 111	273,00
302.15.16	SK 30 - 2,5/16 - 116	294,00
402.15.08	SK 40 - 0,5/8 - 70	199,00
402.15.13	SK 40 - 1,0/13 - 90	190,00
402.15.16	SK 40 - 2,5/16 - 95	195,00
502.15.13	SK 50 - 1,0/13 - 90	257,00
502.15.16	SK 50 - 2,5/16 - 95	273,00



**CNC-Bohrfutter
für Rechts- und Linkslauf**
CNC-Drill chucks for clockwise
and counter clockwise rotation
Mandrins de perçage CNC
pour rotation droite-gauche



Bestell-Nr. Order no. / Référence	Abmessung Size / Dimension	Euro
403.15.08	SK 40 - 0,5/8 - 70	209,00
403.15.13	SK 40 - 1,0/13 - 90	200,00
403.15.16	SK 40 - 2,5/16 - 95	205,00
503.15.13	SK 50 - 1,0/13 - 90	268,00
503.15.16	SK 50 - 2,5/16 - 95	283,00



Bohrfutteraufnahme DIN 238
Drill chuck adaptors DIN 238
Arbres pour mandrins de perçage
DIN 238



Bestell-Nr. Order no. / Référence	Abmessung Size / Dimension	Euro
302.14.12	SK 30 - B12	52,00
302.14.16	SK 30 - B16	52,00
402.14.12	SK 40 - B12	49,00
402.14.16	SK 40 - B16	49,00
402.14.18	SK 40 - B18	49,00
502.14.12	SK 50 - B12	64,00
502.14.16	SK 50 - B16	64,00
502.14.18	SK 50 - B18	64,00



Gewuchtete Ausführung
Balanced type
Type équilibré



Bestell-Nr. Order no. / Réf.	Abmessung Size / Dimension	Euro
Wuchten auf G 2,5 von vorgewuchteten DOLFAMEX-Werkzeugen Balancing at G 2.5 of pre-balanced DOLFAMEX-tools Équilibrage sur G 2,5 d'outils DOLFAMEX pré-équilibrés		
W25	Ohne Wuchtprotokoll Without balancing report Sans protocole d'équilibrage	15,00
W25.2	Mit Wuchtprotokoll With balancing report Avec protocole d'équilibrage	19,00
Wuchten von nicht vorgewuchteten Werkzeugen Balancing of unbalanced tools Équilibrage d'outils non-équilibrés		
W25.1	Ohne Wuchtprotokoll Without balancing report Sans protocole d'équilibrage	28,00



Toolholders DIN ISO 7388-1 (formerly DIN 69871)

Porte-outils DIN ISO 7388-1 (l'ancien DIN 69871)



Gewindeschneid-Schnellwechselfutter mit Längenausgleich auf Druck und Zug

Quick change tapping chucks with length compensation on compression and expansion

Mandrins de taraudage à changement rapide avec compensation longitudinale à la compression et traction



Bestell-Nr. Order no. / Référence	Abmessung Size / Dimension	Euro
302.16.12	SK 30 - M3 / M14 Gr. 1	208,00
302.16.20	SK 30 - M5 / M22 Gr. 2	222,00
402.16.12	SK 40 - M3 / M14 Gr. 1	198,00
402.16.20	SK 40 - M5 / M22 Gr. 2	212,00
402.16.36	SK 40 - M14 / M36 Gr. 3	321,00
502.16.12	SK 50 - M3 / M14 Gr. 1	252,00
502.16.20	SK 50 - M5 / M22 Gr. 2	265,00
502.16.36	SK 50 - M14 / M36 Gr. 3	374,00



Gewindeschneid-Schnellwechselfutter ohne Längenausgleich auf Druck und Zug

Quick-change tapping chucks without length compensation on compression and expansion

Mandrins de taraudage à changement rapide sans compensation longitudinale à la compression et traction



Bestell-Nr. Order no. / Référence	Abmessung Size / Dimension	Euro
302.16.12.1	SK 30 - M3 / M14 Gr. 1	160,00
302.16.20.1	SK 30 - M5 / M22 Gr. 2	171,00
402.16.12.1	SK 40 - M3 / M14 Gr. 1	150,00
402.16.20.1	SK 40 - M5 / M22 Gr. 2	161,00
402.16.36.1	SK 40 - M14 / M36 Gr. 3	247,00
502.16.12.1	SK 50 - M3 / M14 Gr. 1	203,00
502.16.20.1	SK 50 - M5 / M22 Gr. 2	217,00
502.16.36.1	SK 50 - M14 / M36 Gr. 3	277,00



Gewindeschneidfutter für Synchronisation für Spannzangen ISO 15488 (DIN 6499) System ER

Tapping chucks for synchronisation for collets ISO 15488 (DIN 6499) ER-system

Mandrins de taraudage pour synchronisation pour pinces ISO 15488 (DIN 6499) système ER



Bestell-Nr. Order no. / Référence	Abmessung Size / Dimension	Euro
403.16.02.10 ¹	SK 40 - ER16 - 79	292,00
403.16.02.10.M ²	SK 40 - ER16 - 79	292,00
403.16.02.13	SK 40 - ER20 - 80	300,00
403.16.02.16	SK 40 - ER25 - 84	300,00
403.16.02.20	SK 40 - ER32 - 95	300,00
403.16.02.26	SK 40 - ER40 - 120	319,00
503.16.02.10 ¹	SK 50 - ER16 - 79	319,00
503.16.02.10.M ²	SK 50 - ER16 - 79	319,00
503.16.02.10.1.M ²	SK 50 - ER16 - 90	319,00
503.16.02.13	SK 50 - ER20 - 80	319,00
503.16.02.16	SK 50 - ER25 - 84	319,00
503.16.02.20	SK 50 - ER32 - 95	345,00
503.16.02.26	SK 50 - ER40 - 105	348,00

¹ Sechskantmutter
¹ Hexagonal clamping nut
¹ Écrous hexagonal

² Minimutter
² Mini nut
² Écrous mini



Hydro-Dehnspannfutter schlanke Ausführung

Hydraulic expansion chucks slim design

Mandrins expansibles hydrauliques type élancé



Bestell-Nr. Order no. / Référence	Abmessung Size / Dimension	Euro
403.HSL06.160	SK 40 - 06 - 160	439,00
403.HSL08.160	SK 40 - 08 - 160	439,00
403.HSL10.160	SK 40 - 10 - 160	439,00
403.HSL12.160	SK 40 - 12 - 160	439,00





Werkzeugaufnahmen DIN ISO 7388-1 (ehemals DIN 69871)

Toolholders DIN ISO 7388-1 (formerly DIN 69871)

Porte-outils DIN ISO 7388-1 (l'ancien DIN 69871)

1



Hydro-Dehnspannfutter
Hydraulic expansion chucks
Mandrins expansibles hydrauliques



Bestell-Nr. Order no. / Référence	Abmessung Size / Dimension	Euro
302.H06 *	SK 30 - 06 - 60	280,00
302.H08 *	SK 30 - 08 - 64	280,00
302.H10 *	SK 30 - 10 - 72	280,00
302.H12 *	SK 30 - 12 - 72	280,00
302.H14 *	SK 30 - 14 - 72	280,00
302.H16 *	SK 30 - 16 - 90	280,00
302.H18 *	SK 30 - 18 - 90	280,00
302.H20 *	SK 30 - 20 - 90	280,00
403.H06	SK 40 - 06 - 68	269,00
403.H08	SK 40 - 08 - 68	269,00
403.H10	SK 40 - 10 - 72	269,00
403.H12	SK 40 - 12 - 77	269,00
403.H14	SK 40 - 14 - 77	269,00
403.H16	SK 40 - 16 - 80	269,00
403.H18	SK 40 - 18 - 80	269,00
403.H20	SK 40 - 20 - 82	269,00
403.H25	SK 40 - 25 - 117	292,00
403.H32	SK 40 - 32 - 117	292,00
403.H06.1	SK 40 - 06 - 110	308,00
403.H08.1	SK 40 - 08 - 110	308,00
403.H10.1	SK 40 - 10 - 110	308,00
403.H12.1	SK 40 - 12 - 110	308,00
403.H14.1	SK 40 - 14 - 110	308,00
403.H16.1	SK 40 - 16 - 110	308,00
403.H18.1	SK 40 - 18 - 110	308,00
403.H20.1	SK 40 - 20 - 110	308,00
403.H06.2	SK 40 - 06 - 150	439,00
403.H08.2	SK 40 - 08 - 150	439,00
403.H10.2	SK 40 - 10 - 150	439,00
403.H12.2	SK 40 - 12 - 150	439,00
403.H14.2	SK 40 - 14 - 150	439,00
403.H16.2	SK 40 - 16 - 150	439,00
403.H18.2	SK 40 - 18 - 150	439,00
403.H20.2	SK 40 - 20 - 150	439,00
403.H25.2	SK 40 - 25 - 150	449,00

* Form AD | * Form AD | * Forme AD

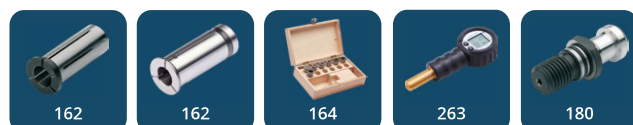

Hydro-Dehnspannfutter
Hydraulic expansion chucks
Mandrins expansibles hydrauliques



Bestell-Nr. Order no. / Référence	Abmessung Size / Dimension	Euro
503.H06	SK 50 - 06 - 68	384,00
503.H08	SK 50 - 08 - 68	384,00
503.H10	SK 50 - 10 - 72	384,00
503.H12	SK 50 - 12 - 77	384,00
503.H14	SK 50 - 14 - 77	384,00
503.H16	SK 50 - 16 - 80	384,00
503.H18	SK 50 - 18 - 80	384,00
503.H20	SK 50 - 20 - 82	384,00
503.H25	SK 50 - 25 - 87	409,00
503.H32	SK 50 - 32 - 91	409,00
503.H06.1	SK 50 - 06 - 110	441,00
503.H08.1	SK 50 - 08 - 110	441,00
503.H10.1	SK 50 - 10 - 110	441,00
503.H12.1	SK 50 - 12 - 110	441,00
503.H14.1	SK 50 - 14 - 110	441,00
503.H16.1	SK 50 - 16 - 110	441,00
503.H18.1	SK 50 - 18 - 110	441,00
503.H20.1	SK 50 - 20 - 110	441,00
503.H25.1	SK 50 - 25 - 110	441,00
503.H32.1	SK 50 - 32 - 110	441,00
503.H06.2	SK 50 - 06 - 150	549,00
503.H08.2	SK 50 - 08 - 150	549,00
503.H10.2	SK 50 - 10 - 150	549,00
503.H12.2	SK 50 - 12 - 150	549,00
503.H14.2	SK 50 - 14 - 150	549,00
503.H16.2	SK 50 - 16 - 150	549,00
503.H18.2	SK 50 - 18 - 150	549,00
503.H20.2	SK 50 - 20 - 150	549,00
503.H25.2	SK 50 - 25 - 150	559,00
503.H32.2	SK 50 - 32 - 150	569,00
503.H40.2	SK 50 - 40 - 150	579,00





Toolholders DIN ISO 7388-1 (formerly DIN 69871)

Porte-outils DIN ISO 7388-1 (l'ancien DIN 69871)

1



Schrumpffutter 4,5°
Shrink chucks 4,5°
Mandrins de frettage 4,5°

ISO 7388-1	Form AD	≤ 3µm	G2,5 25,000 min ⁻¹	RFID Chip	h6
------------	---------	-------	-------------------------------	-----------	----



Schrumpffutter 4,5°
Shrink chucks 4,5°
Mandrins de frettage 4,5°

ISO 7388-1	Form AD/AF (AD/B)	≤ 3µm	G2,5 25,000 min ⁻¹	RFID Chip	h6
------------	-------------------	-------	-------------------------------	-----------	----

Bestell-Nr. Order no. / Référence	Abmessung Size / Dimension	Euro
302.70.03	SK 30 - 03 - 80	126,00
302.70.04	SK 30 - 04 - 80	126,00
302.70.05	SK 30 - 05 - 80	126,00
302.70.06	SK 30 - 06 - 80	126,00
302.70.08	SK 30 - 08 - 80	126,00
302.70.10	SK 30 - 10 - 80	126,00
302.70.12	SK 30 - 12 - 100	126,00
302.70.14	SK 30 - 14 - 100	126,00
302.70.16	SK 30 - 16 - 100	126,00
302.70.18	SK 30 - 18 - 100	126,00
302.70.20	SK 30 - 20 - 100	126,00

Bestell-Nr. Order no. / Référence	Abmessung Size / Dimension	Euro
403.70.03	SK 40 - 03 - 80	119,00
403.70.04	SK 40 - 04 - 80	119,00
403.70.05	SK 40 - 05 - 80	119,00
403.70.06	SK 40 - 06 - 80	99,00
403.70.08	SK 40 - 08 - 80	99,00
403.70.10	SK 40 - 10 - 80	99,00
403.70.12	SK 40 - 12 - 80	99,00
403.70.14	SK 40 - 14 - 80	99,00
403.70.16	SK 40 - 16 - 80	99,00
403.70.18	SK 40 - 18 - 80	99,00
403.70.20	SK 40 - 20 - 80	99,00
403.70.25	SK 40 - 25 - 100	99,00
403.70.32	SK 40 - 32 - 100	99,00



403.70.03.1	SK 40 - 03 - 120	136,00
403.70.04.1	SK 40 - 04 - 120	136,00
403.70.05.1	SK 40 - 05 - 120	136,00
403.70.06.1	SK 40 - 06 - 120	119,00
403.70.08.1	SK 40 - 08 - 120	119,00
403.70.10.1	SK 40 - 10 - 120	119,00
403.70.12.1	SK 40 - 12 - 120	119,00
403.70.14.1	SK 40 - 14 - 120	119,00
403.70.16.1	SK 40 - 16 - 120	119,00
403.70.18.1	SK 40 - 18 - 120	119,00
403.70.20.1	SK 40 - 20 - 120	119,00



Nachträgliches Erodieren von 2 Kühlkanalbohrungen
Supplementary eroding of 2 cooling channels
Éroder supplémentaire de 2 canaux d'arrosage

Bestell-Nr. Order no. / Référence	Euro
U.KKB	42,00

403.70.03.2	SK 40 - 03 - 160	198,00
403.70.04.2	SK 40 - 04 - 160	198,00
403.70.05.2	SK 40 - 05 - 160	198,00
403.70.06.2	SK 40 - 06 - 160	182,00
403.70.08.2	SK 40 - 08 - 160	182,00
403.70.10.2	SK 40 - 10 - 160	182,00
403.70.12.2	SK 40 - 12 - 160	182,00
403.70.14.2	SK 40 - 14 - 160	182,00
403.70.16.2	SK 40 - 16 - 160	182,00
403.70.18.2	SK 40 - 18 - 160	182,00
403.70.20.2	SK 40 - 20 - 160	182,00
403.70.25.2	SK 40 - 25 - 160	186,00
403.70.32.2	SK 40 - 32 - 160	186,00





Werkzeugaufnahmen DIN ISO 7388-1 (ehemals DIN 69871)

Toolholders DIN ISO 7388-1 (formerly DIN 69871)

Porte-outils DIN ISO 7388-1 (l'ancien DIN 69871)

1



Schrumpffutter 4,5°
Shrink chucks 4,5°
Mandrins de frettage 4,5°

ISO 7388-1 Form AD/AF (AD/B) ≤ 3µm G2,5 25.000 min⁻¹ RFID Chip h6

Bestell-Nr. Order no. / Référence	Abmessung Size / Dimension	Euro
503.71.03	SK 50 - 03 - 80	203,00
503.71.04	SK 50 - 04 - 80	203,00
503.71.05	SK 50 - 05 - 80	203,00
503.71.06	SK 50 - 06 - 80	203,00
503.71.08	SK 50 - 08 - 80	203,00
503.71.10	SK 50 - 10 - 80	203,00
503.71.12	SK 50 - 12 - 80	203,00
503.71.14	SK 50 - 14 - 80	203,00
503.71.16	SK 50 - 16 - 80	203,00
503.71.18	SK 50 - 18 - 80	203,00
503.71.20	SK 50 - 20 - 80	203,00
503.71.25	SK 50 - 25 - 100	216,00
503.71.32	SK 50 - 32 - 100	216,00

503.71.06.1	SK 50 - 06 - 120	224,00
503.71.08.1	SK 50 - 08 - 120	224,00
503.71.10.1	SK 50 - 10 - 120	224,00
503.71.12.1	SK 50 - 12 - 120	224,00
503.71.14.1	SK 50 - 14 - 120	224,00
503.71.16.1	SK 50 - 16 - 120	224,00
503.71.18.1	SK 50 - 18 - 120	224,00
503.71.20.1	SK 50 - 20 - 120	224,00

503.71.06.2	SK 50 - 06 - 160	233,00
503.71.08.2	SK 50 - 08 - 160	233,00
503.71.10.2	SK 50 - 10 - 160	233,00
503.71.12.2	SK 50 - 12 - 160	233,00
503.71.14.2	SK 50 - 14 - 160	233,00
503.71.16.2	SK 50 - 16 - 160	233,00
503.71.18.2	SK 50 - 18 - 160	233,00
503.71.20.2	SK 50 - 20 - 160	233,00
503.71.25.2	SK 50 - 25 - 160	233,00
503.71.32.2	SK 50 - 32 - 160	233,00

503.71.06.3	SK 50 - 06 - 200	260,00
503.71.08.3	SK 50 - 08 - 200	260,00
503.71.10.3	SK 50 - 10 - 200	260,00
503.71.12.3	SK 50 - 12 - 200	260,00
503.71.14.3	SK 50 - 14 - 200	260,00
503.71.16.3	SK 50 - 16 - 200	260,00
503.71.18.3	SK 50 - 18 - 200	260,00
503.71.20.3	SK 50 - 20 - 200	260,00
503.71.25.3	SK 50 - 25 - 200	260,00
503.71.32.3	SK 50 - 32 - 200	260,00



Schrumpffutter 4,5°
mit Kühlkanälen
Shrink chucks 4,5°
with cooling channels
Mandrins de frettage 4,5°
avec canaux d'arrosage

ISO 7388-1 Form AD/AF (AD/B) ≤ 3µm G2,5 25.000 min⁻¹ RFID Chip h6

Bestell-Nr. Order no. / Référence	Abmessung Size / Dimension	Euro
403.70.03.K	SK 40 - 03 - 80	149,00
403.70.04.K	SK 40 - 04 - 80	149,00
403.70.05.K	SK 40 - 05 - 80	149,00
403.70.06.K	SK 40 - 06 - 80	129,00
403.70.08.K	SK 40 - 08 - 80	129,00
403.70.10.K	SK 40 - 10 - 80	129,00
403.70.12.K	SK 40 - 12 - 80	129,00
403.70.14.K	SK 40 - 14 - 80	129,00
403.70.16.K	SK 40 - 16 - 80	129,00
403.70.18.K	SK 40 - 18 - 80	129,00
403.70.20.K	SK 40 - 20 - 80	129,00
403.70.25.K	SK 40 - 25 - 100	135,00
403.70.32.K	SK 40 - 32 - 100	135,00

403.70.03.1.K	SK 40 - 03 - 120	171,00
403.70.04.1.K	SK 40 - 04 - 120	171,00
403.70.05.1.K	SK 40 - 05 - 120	171,00
403.70.06.1.K	SK 40 - 06 - 120	156,00
403.70.08.1.K	SK 40 - 08 - 120	156,00
403.70.10.1.K	SK 40 - 10 - 120	156,00
403.70.12.1.K	SK 40 - 12 - 120	156,00
403.70.14.1.K	SK 40 - 14 - 120	156,00
403.70.16.1.K	SK 40 - 16 - 120	156,00
403.70.18.1.K	SK 40 - 18 - 120	156,00
403.70.20.1.K	SK 40 - 20 - 120	156,00

503.71.06.K	SK 50 - 06 - 80	234,00
503.71.08.K	SK 50 - 08 - 80	234,00
503.71.10.K	SK 50 - 10 - 80	234,00
503.71.12.K	SK 50 - 12 - 80	234,00
503.71.14.K	SK 50 - 14 - 80	234,00
503.71.16.K	SK 50 - 16 - 80	234,00
503.71.18.K	SK 50 - 18 - 80	234,00
503.71.20.K	SK 50 - 20 - 80	234,00
503.71.25.K	SK 50 - 25 - 100	245,00
503.71.32.K	SK 50 - 32 - 100	245,00



Toolholders DIN ISO 7388-1 (formerly DIN 69871)

Porte-outils DIN ISO 7388-1 (l'ancien DIN 69871)



Schrumpffutter 3° - schlank
Shrink chucks 3° - slim
 Mandrins de frettage 3° - élancé



Bestell-Nr. Order no. / Référence	Abmessung Size / Dimension	Euro
403.72.03	SK 40 - 03 - 80	129,00
403.72.04	SK 40 - 04 - 80	129,00
403.72.05	SK 40 - 05 - 80	129,00
403.72.06	SK 40 - 06 - 80	109,00
403.72.08	SK 40 - 08 - 80	109,00
403.72.10	SK 40 - 10 - 80	109,00
403.72.12	SK 40 - 12 - 80	109,00
403.72.03.1	SK 40 - 03 - 120	159,00
403.72.04.1	SK 40 - 04 - 120	159,00
403.72.05.1	SK 40 - 05 - 120	159,00
403.72.06.1	SK 40 - 06 - 120	135,00
403.72.08.1	SK 40 - 08 - 120	135,00
403.72.10.1	SK 40 - 10 - 120	135,00
403.72.12.1	SK 40 - 12 - 120	135,00
403.72.06.2	SK 40 - 06 - 160	197,00
403.72.08.2	SK 40 - 08 - 160	197,00
403.72.10.2	SK 40 - 10 - 160	197,00
403.72.12.2	SK 40 - 12 - 160	197,00



Nachträgliches Erodieren von 2 Kühlkanalbohrungen
Supplementary eroding of 2 cooling channels
 Éroder supplémentaire de 2 canaux d'arrosage

Bestell-Nr. Order no. / Référence	Euro
U.KKB	42,00



Schrumpferverlängerungen (mit Anschlag)
Shrink fit extensions (with end stop)
 Rallonges de frettage (avec butée)



Bestell-Nr. Order no. / Référence	Abmessung Size / Dimension	Euro
120.70.03	20 - 03 - 150	95,00
120.70.04	20 - 04 - 150	95,00
120.70.05	20 - 05 - 150	95,00
120.70.06*	20 - 06 - 150	95,00
120.70.08*	20 - 08 - 150	95,00
120.70.10*	20 - 10 - 150	95,00
120.70.12*	20 - 12 - 150	95,00

* mit Anschlag | * with end stop | * avec butée

Gewuchtete Ausführung Balanced type Type équilibré

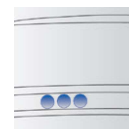

Bestell-Nr. Order no. / Réf.	Abmessung Size / Dimension	Euro
Wuchten auf G 2,5 von vorgewuchteten DOLFAMEX-Werkzeugen <i>Balancing at G 2.5 of pre-balanced DOLFAMEX-tools</i> Equilibrage sur G 2,5 d'outils DOLFAMEX pré-équilibrés		
W25	Ohne Wuchtprotokoll Without balancing report Sans protocole d'équilibrage	15,00
W25.2	Mit Wuchtprotokoll With balancing report Avec protocole d'équilibrage	19,00

Wuchten von nicht vorgewuchteten Werkzeugen Balancing of unbalanced tools Equilibrage d'outils non-équilibrés

W25.1	Ohne Wuchtprotokoll Without balancing report Sans protocole d'équilibrage	28,00
-------	---	-------